

Caixa R0

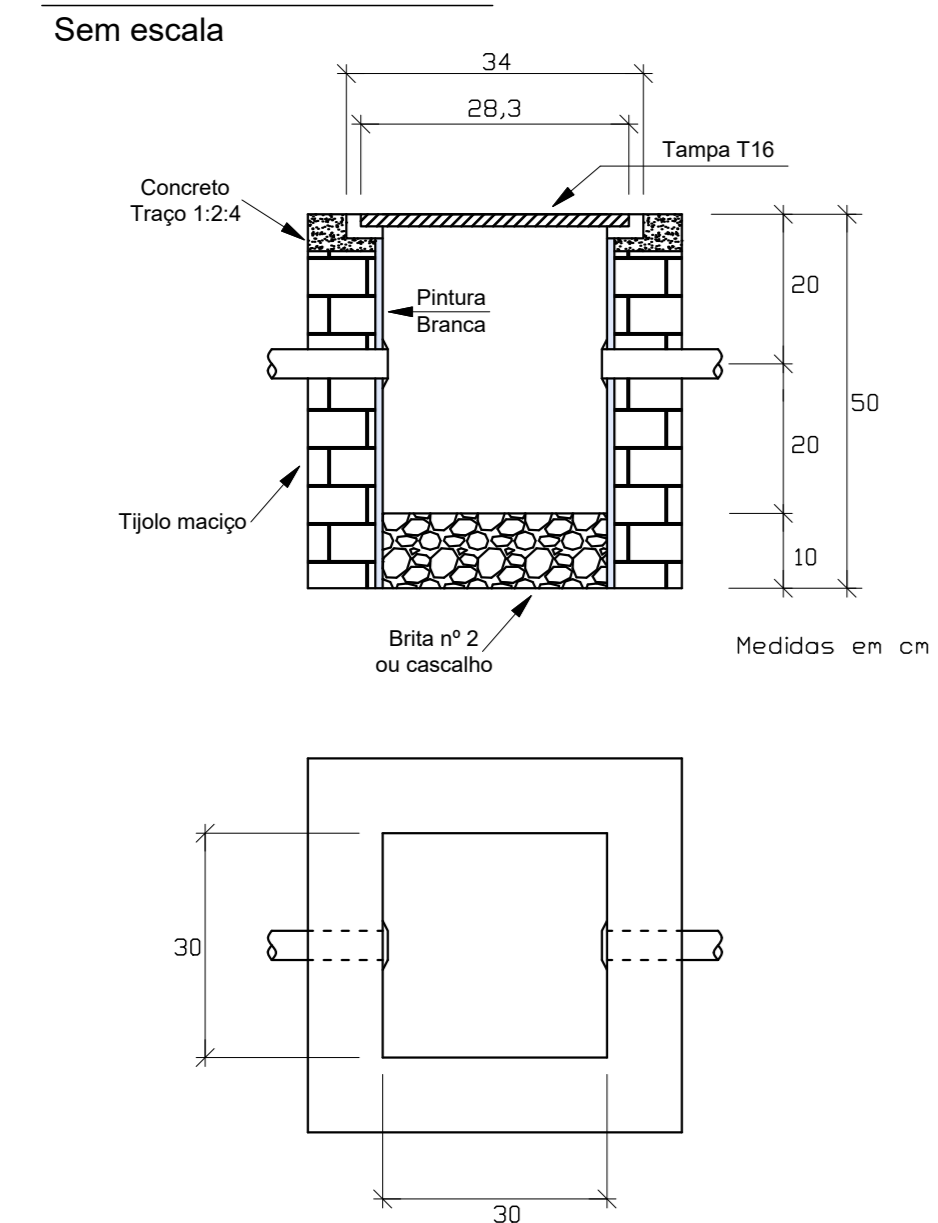

Caixa T33

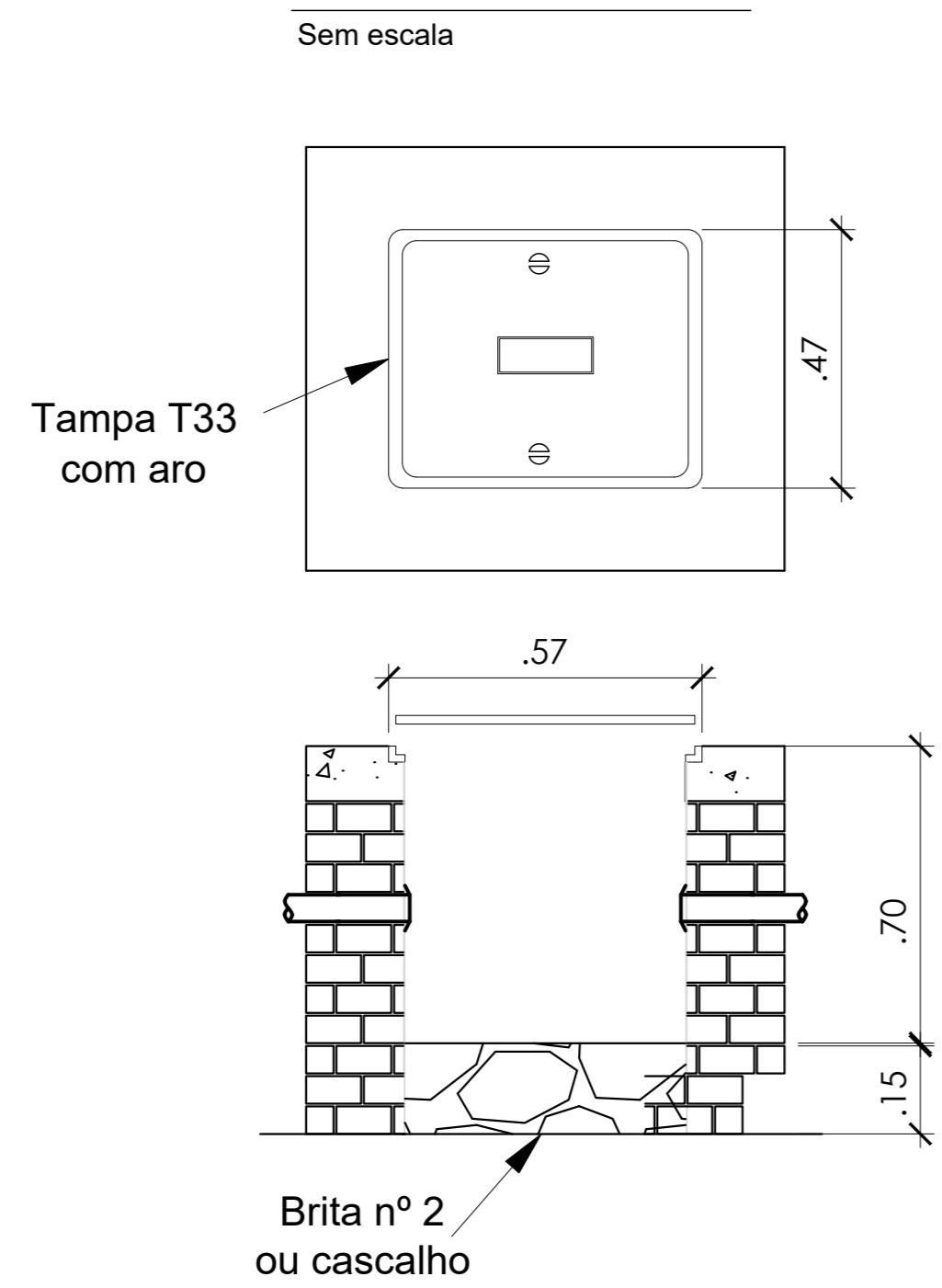

Assentamento das caixas R1DP, R2DP, R3DP e R4DP

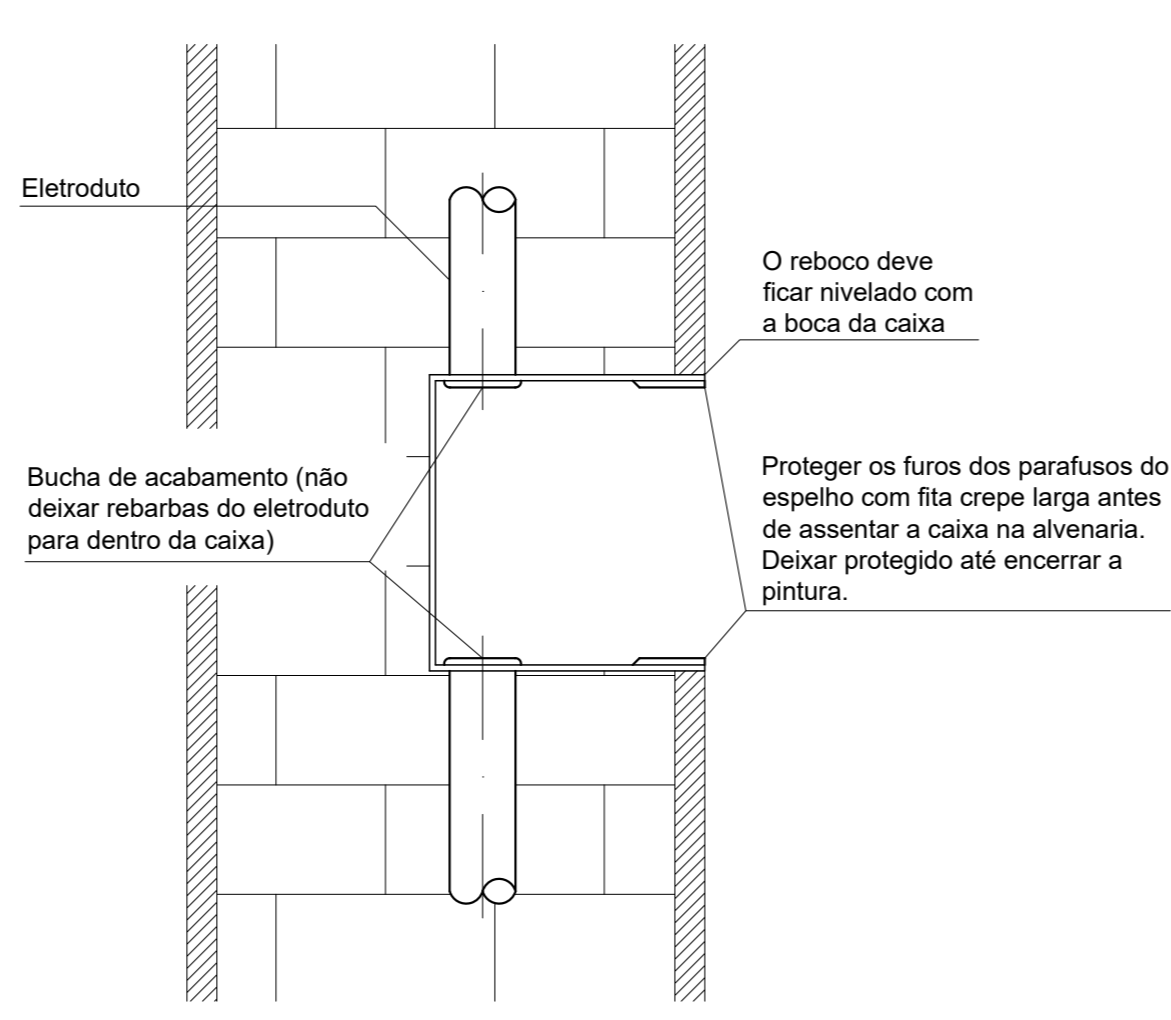

Caixa RE1

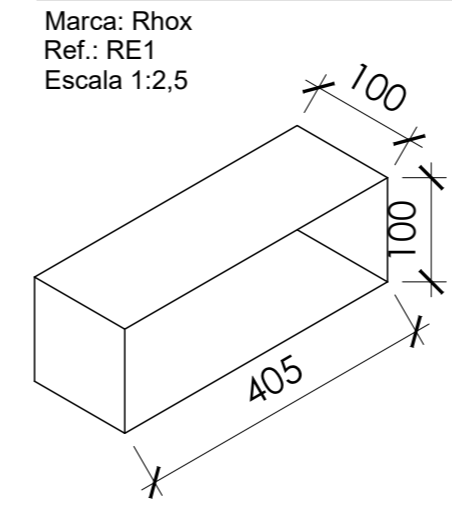

Caixa RE2

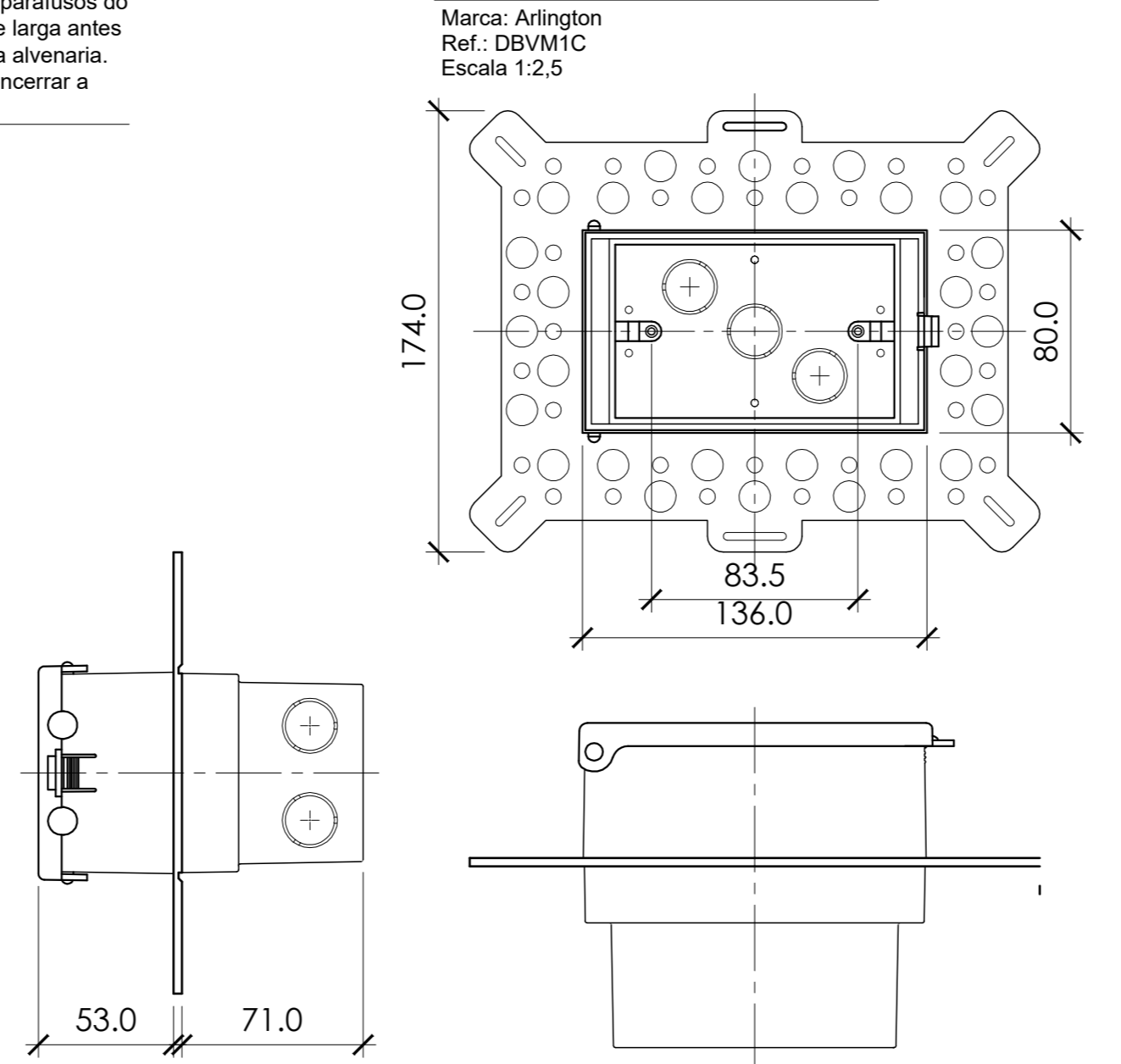

Caixa R1DP

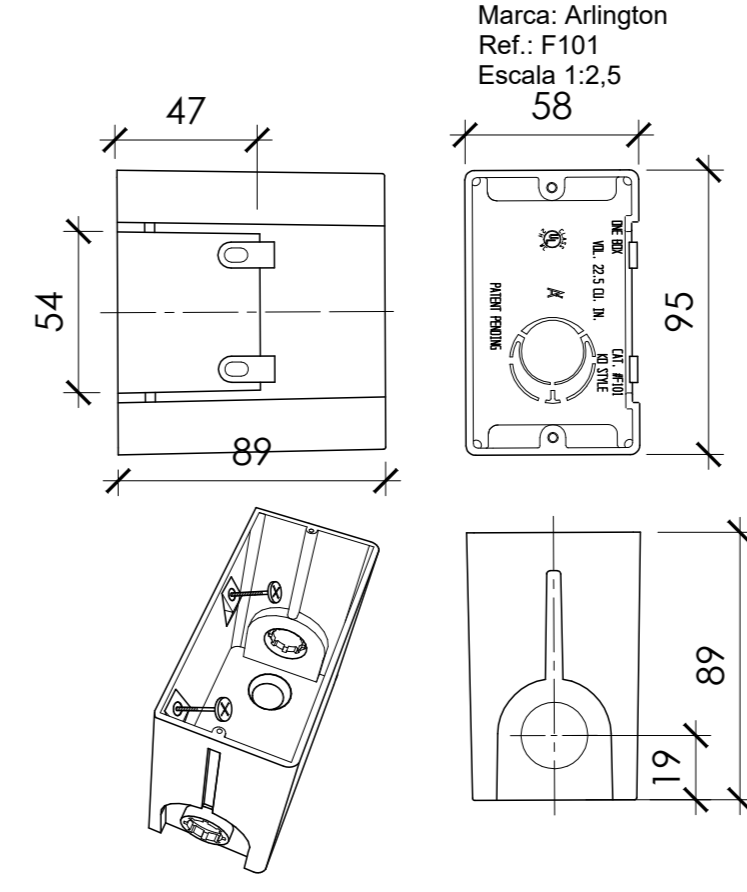

Caixa R2DP

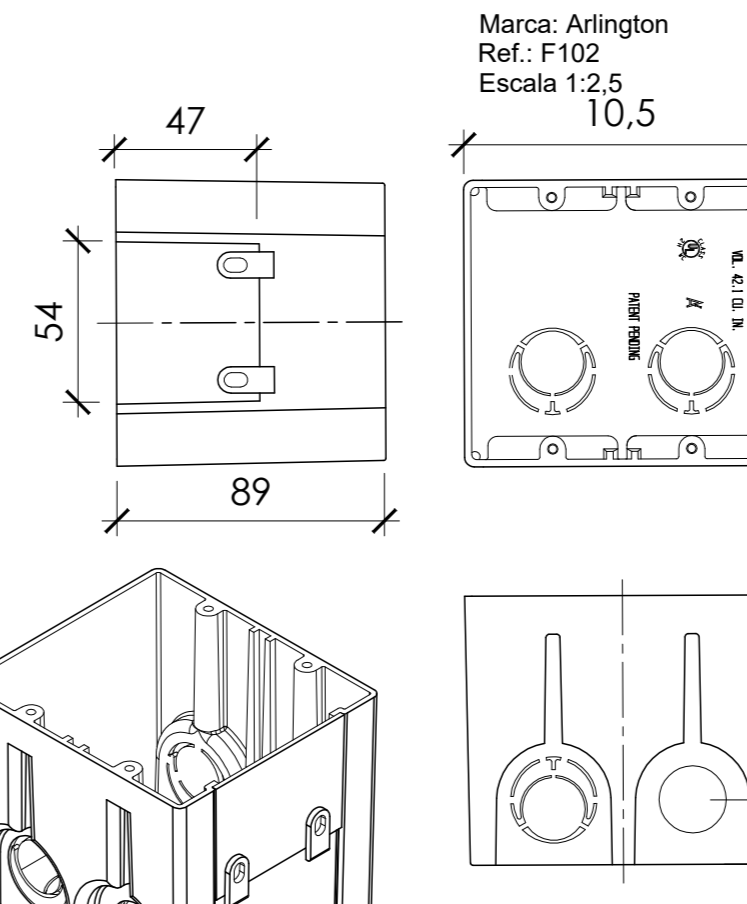

Caixa tipo 0L

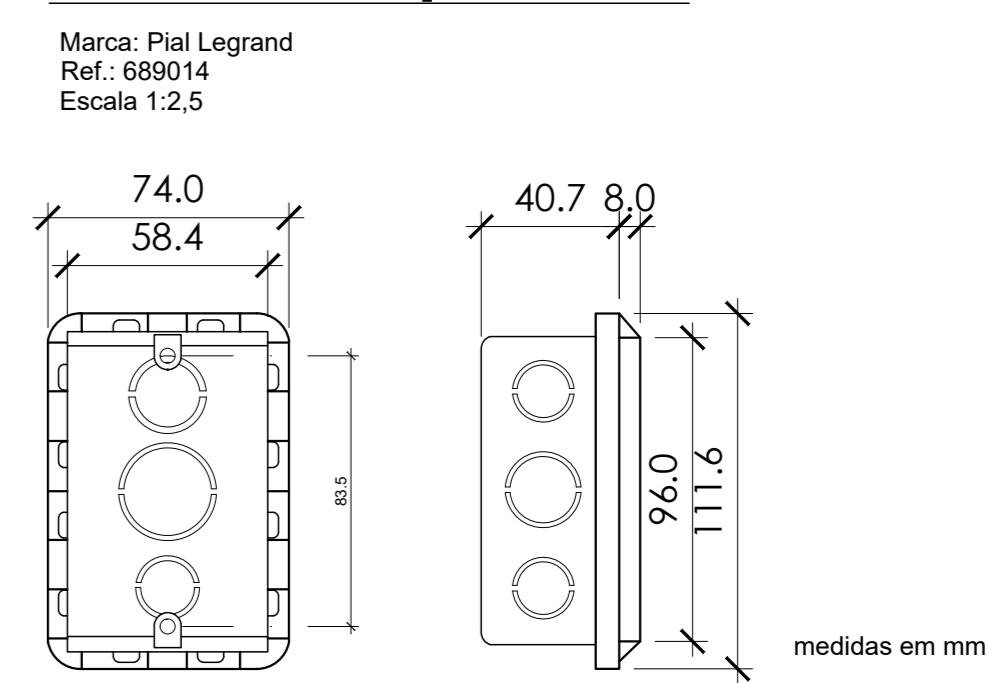

Caixa tipo 1L

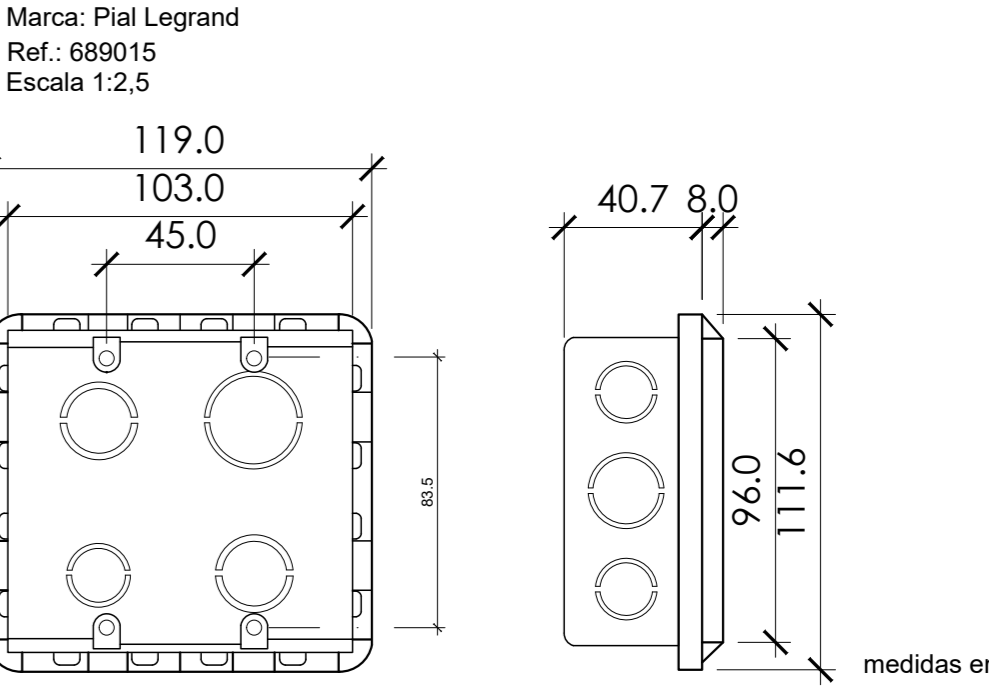

Caixa R1

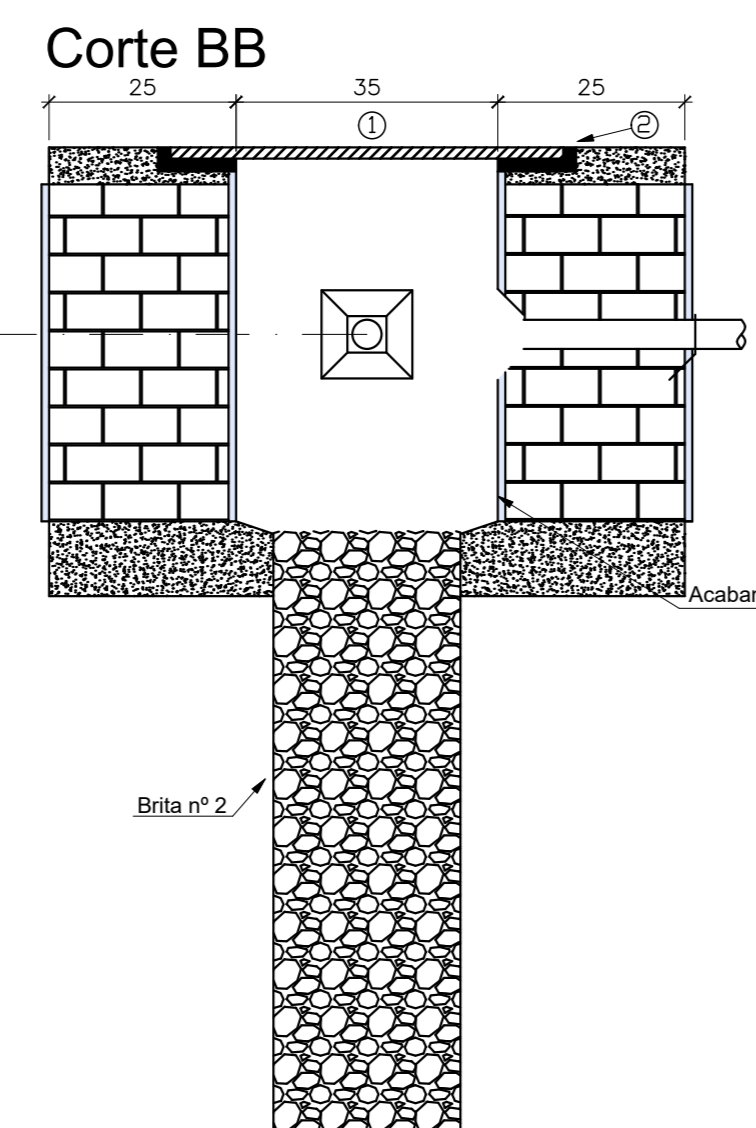
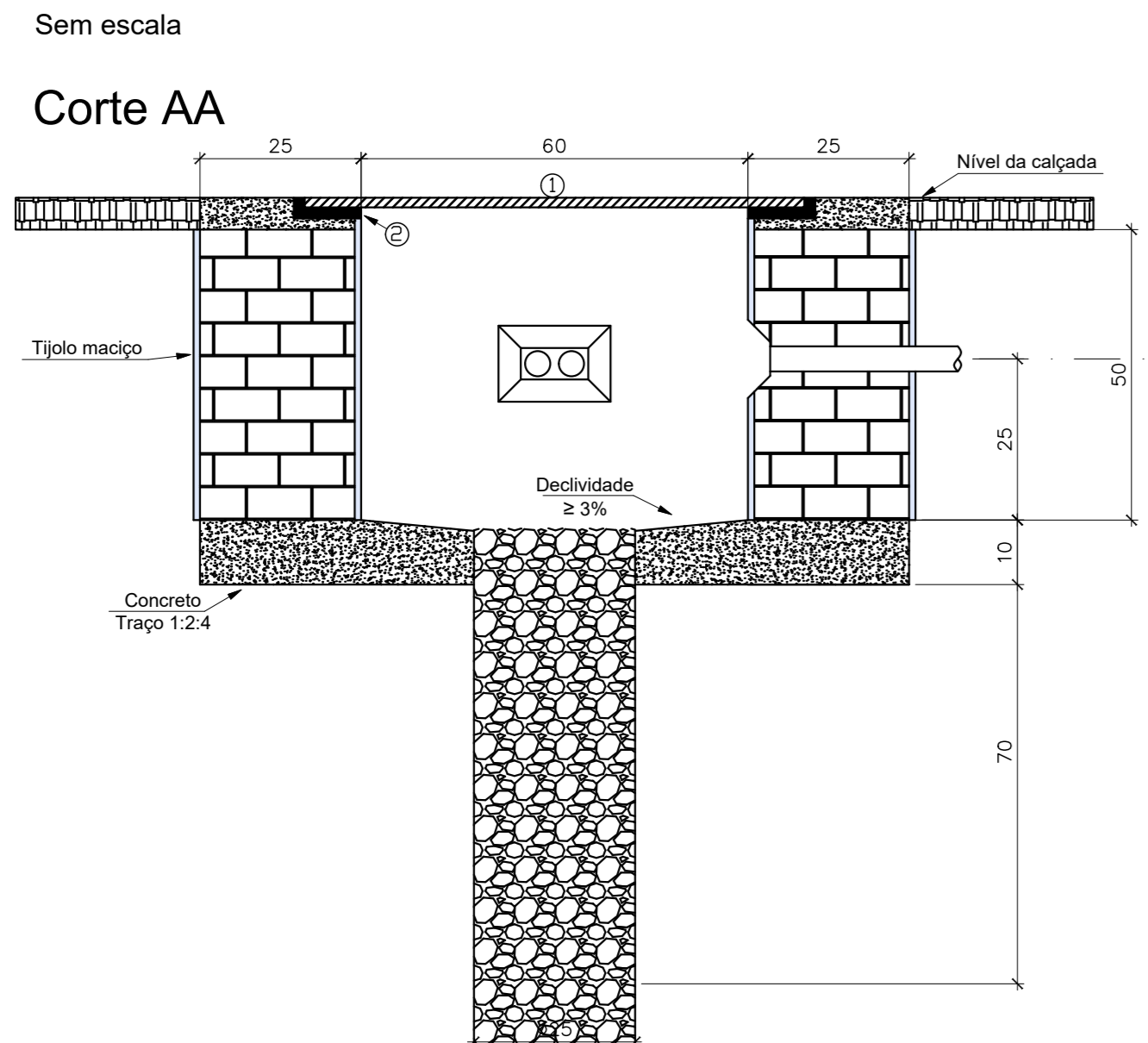

Suporte de fixação

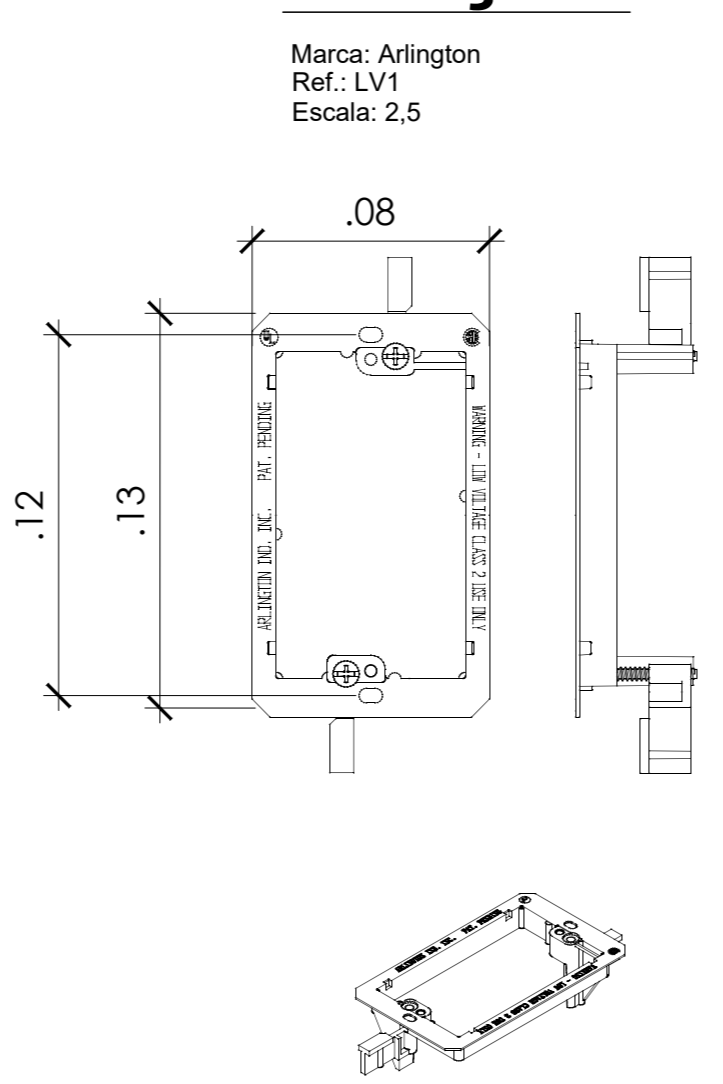

Caixa RE3

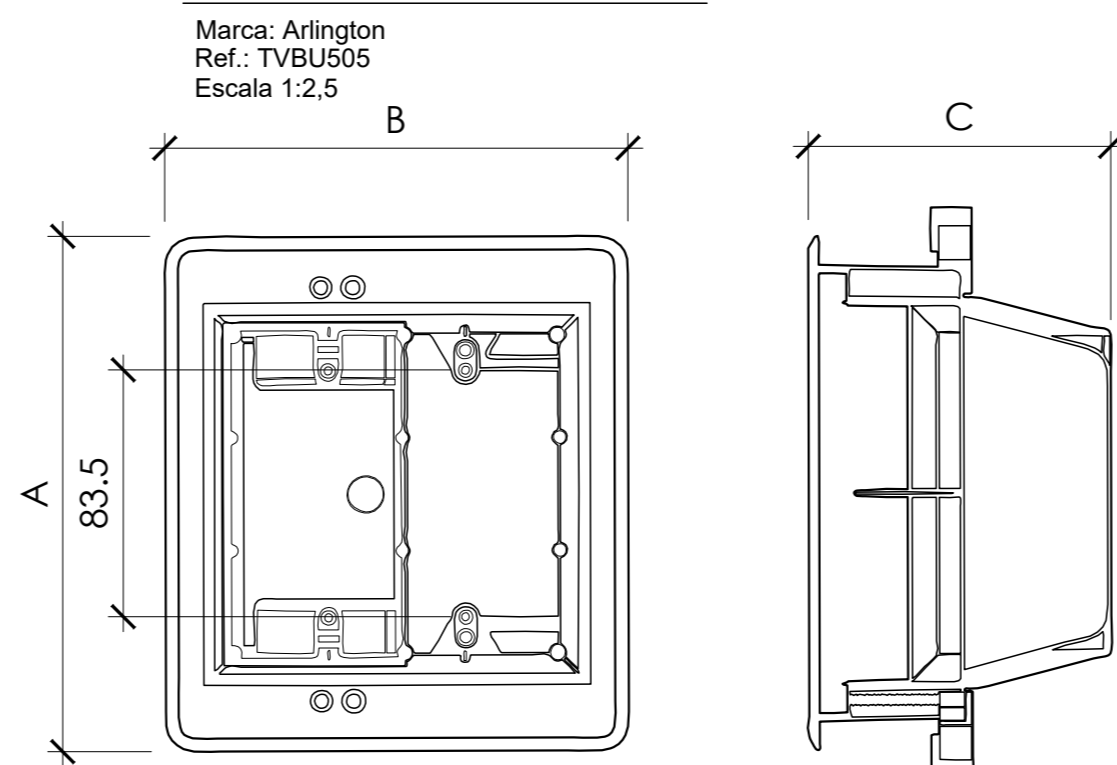

Caixa RE4

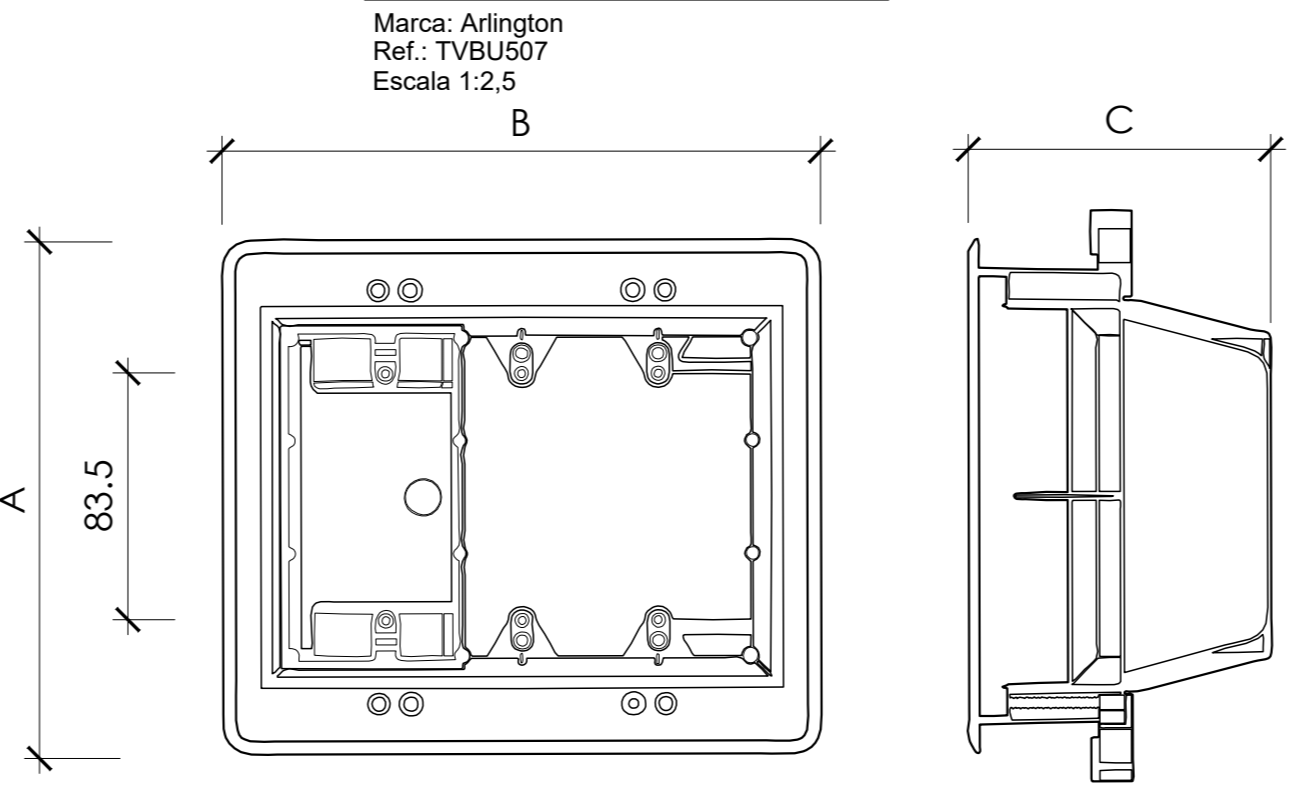

Tipo de caixa	Dimensões em milímetros		
	A	B	C
RE3	174	160	96
RE4	202	174	100

Caixa R3DP

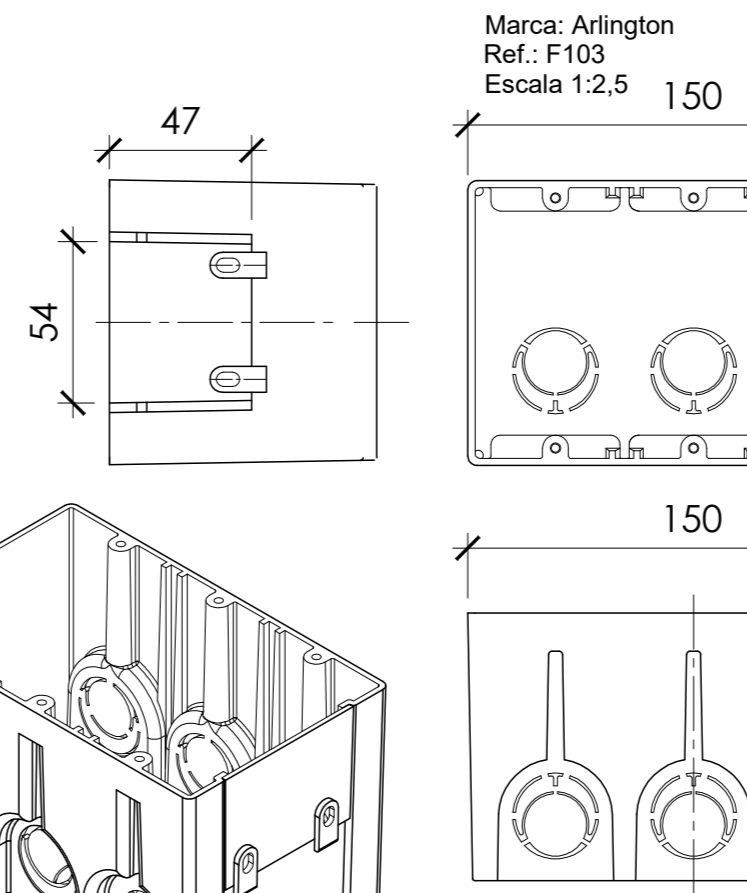

Caixa R4DP

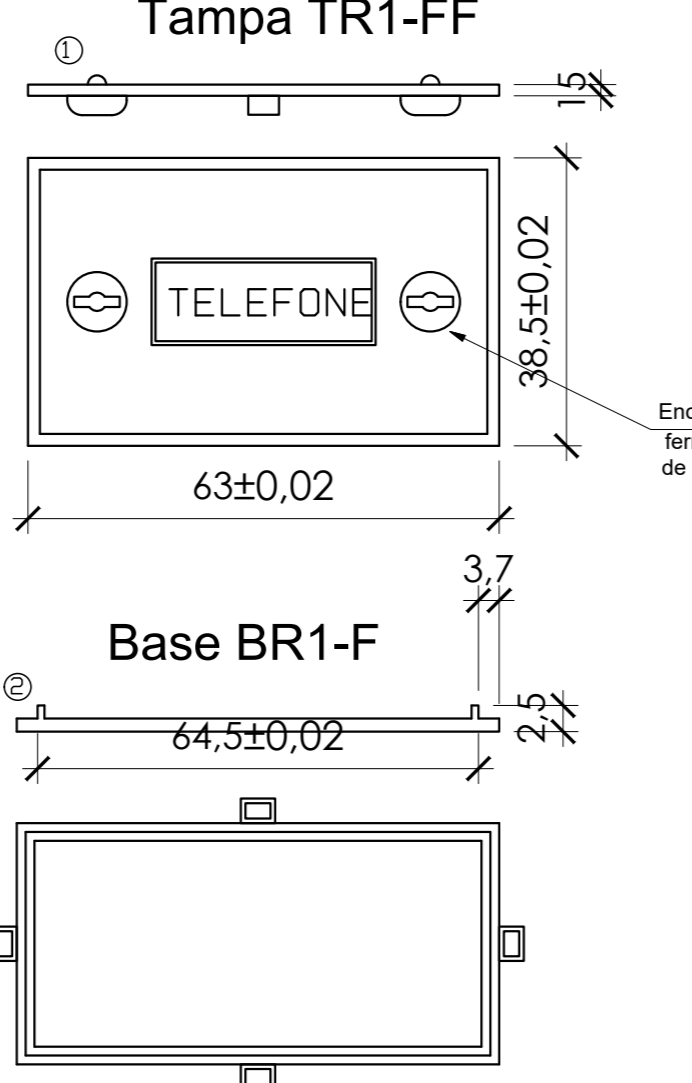
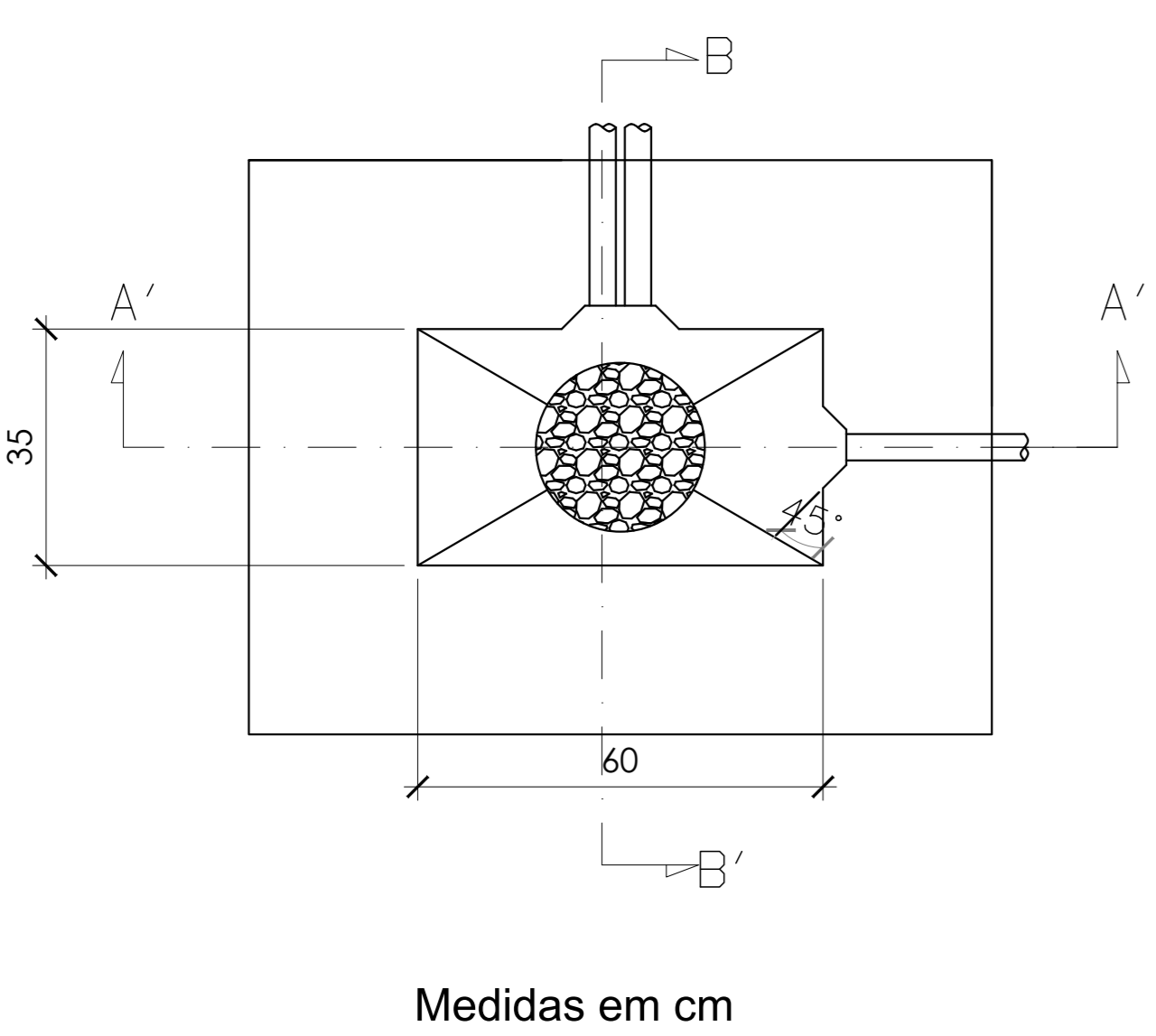
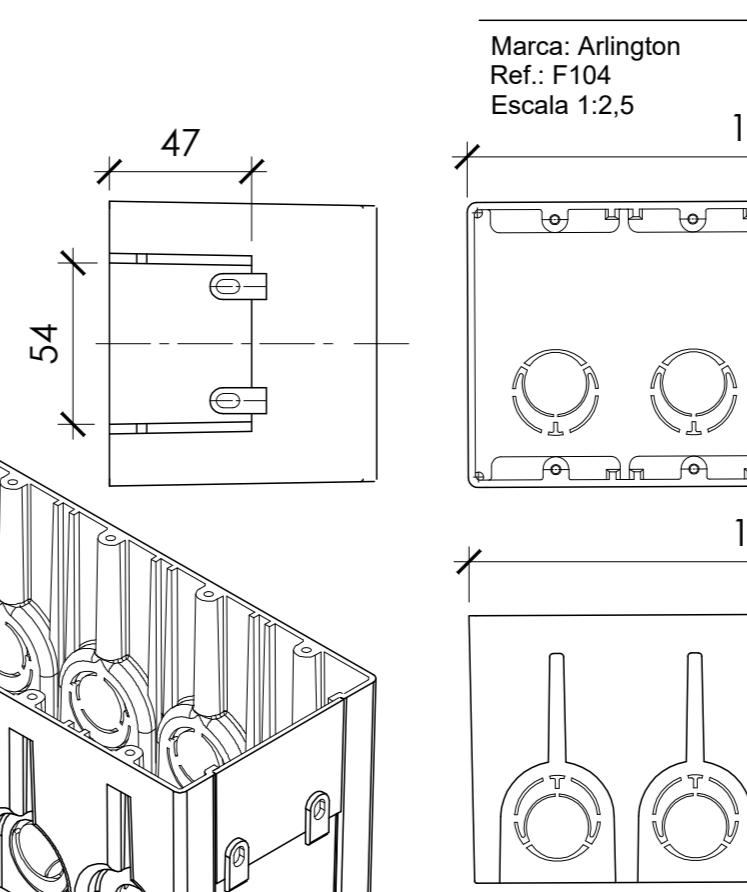

Medidas em cm

LEGENDAS:

- ALVENARIA EXISTENTE
- ALVENARIA A DEMOLIR
- ALVENARIA A CONSTRUIR
- GESSO ACARTONADO EXISTENTE
- GESSO ACARTONADO A CONSTRUIR
- PAREDE DIVISÓRIA A CONSTRUIR

OBSERVAÇÕES:
CONFERRIR DIMENSÕES NO LOCAL

REVISÃO	MODIFICAÇÃO	DATA	PROJETISTA	DESENHISTA	APROVO
04					
03					
02					
01					

henrix ARQUITETURA

CONSELHO FEDERAL DE FISIOTERAPIA E TERAPIA OCUPACIONAL
C O F F I T O
SIA TRECHO 17, VIA IA 4, LOTE 810
BRASILIA - DF

ENCAMINHAMENTO AUDITÓRIO ED. SEDE

CABEAMENTO AUDITÓRIO CAIXAS

ÁREA PROJ. m²
ÁREA TOTAL m²
DATA JUN/2022

COORDENADOR: HENRIQUES
CATEGORIA: PROJETO EXECUTIVO
ESCALA: INDICADA